

OVENS - FAGOR
 901010012
6H-50 X

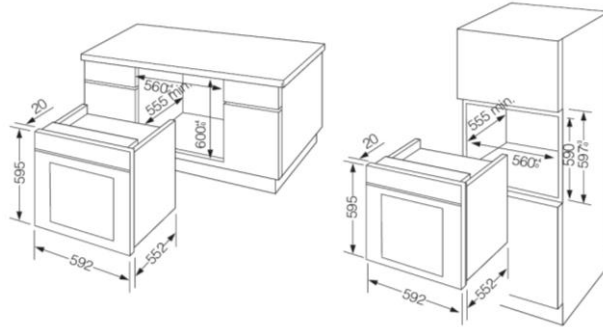

01 - GENERAL FEATURES	DETAILS
FRONT COLOR	STAINLESS STEEL
COOKING METHOD	MULTIFUNCTION OVEN
COOKING PROGRAMS	8
USABLE VOLUME (L) CAVITY 1	51 L
STEAM OUTLET SYSTEM	VENTILATED OUTLET
CONTROL SETTING DEVICES	FIXED KNOB
KNOBS COLOR	STAINLESS STEEL LOOK
02 - EQUIPMENT	DETAILS
FUNCTIONS/TEMPERATURE SELECTOR	YES
TEMPERATURE CONTROL	MECHANIC CONTROL
VARIABLE GRILL	2 POSITIONS
FOLD DOWN GRILL	YES
CLEANING SYSTEM	"TOP SLIDE" ENAMEL
TURN SPIT	NO
TIME CONTROL	ELECTRONIC PROGRAMMER START/STOP (3 BUTTONS)
POWER SUPPLY CABLE	YES
TIME-SETTING OPTIONS	START/STOP
PILOT INDICATOR 'IN OPERATION'	ORANGE
THERMOSTAT PILOT INDICATOR	ORANGE
03- SAFETY	DETAILS
SAFETY DOOR	2 GLASSES
SAFETY THERMOSTAT	YES
CHILD SAFETY FUNCTIONS BLOCKING	NO
AUTOMATIC DOOR LOCK (PYROLISIS FUNCTION)	NO
04 - ACCESSORIES	DETAILS
ENAMELLED TRAY	1
ENAMELLED DEEP TRAY	1
CHROMED GRID (SAFETY POSITION)	0
M PULL-SYSTEM GRID (SAFETY POSITION)	2
CHROMED GRID	2
05 - ENERGY INPUT	DETAILS
ELECTRICAL CONNECTION RATING (KW)	2.670 KW
GRILL POWER (KW)	2.60 KW
VOLTAGE / FREQUENCE (V/HZ)	230V/50HZ
CURRENT (AMP.)	16A
06 - ENERGETIC DATAS	DETAILS
ENERGY EFFICIENCY	A
CONVENTIONAL ENERGY CONSUMPTION	0.790
M VENTILATED CONVENTIONAL ENERGY CONSUMPTION	0.74
07 - LOGICITIC DATAS	DETAILS
EXTERNAL DIMENSIONS (W x D) (MM)	592 x 595
INTERNAL DIMENSIONS (H x W x D) (MM)	322 x 420 x 380