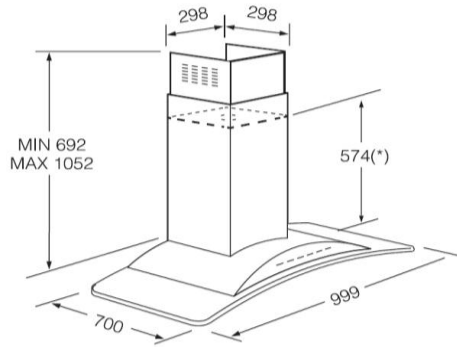

HOODS - FAGOR

932013161

6CFT-90VISLA

01 - GENERAL DESCRIPTION		DETAILS
TYPE		CONVENTIONAL
INSTALATION		ISLE
DOUBLE TURBINE MOTOR		YES
M ASPIRACION PERIMETRAL		NO
MOTOR LOCATION		INTEGRATED
NUMBER OF SPEED SETTINGS		3
BOOST POSITION		NO
CONTROL PANEL		SOFT BUTTONS
TYPE OF LAMPS		HALOGEN LIGHT
EVACUATION MODE		YES
RECYCLING MODE		YES (CONVERTIBLE)
MINIMUM DISTANCE FROM GAS HOBS (MM)		650
MINIMUM DISTANCE FROM ELECTRIC HOBS (MM)		550
M EASY TO CLEAN INTERNAL DESIGN		NO
M O2 PURIFICATION		NO
02 - STANDARD EQUIPMENT		DETAILS
TYPE OF CONTROL		ELECTRONIC
M DISPLAY LCD		NO
SPEED DISPLAY		NO
AUTOMATIC MOTOR SWITCH OFF		NO
NUMBER OF LAMPS		4
GREASE FILTER MATERIAL		MODULAR METALIC FILTER
NUMBER OF FILTERS		1
NO-RETURN AIRFLOW FLAP		YES
FILTER SATURATION SIGNALING		NO
M AUTOMATIC OPERATION SENSOR		NO
M ADJUSTABLE LIGHTING INTENSITY		NO
M INSULATION SYSTEM		NO
03 - TECHNICAL DATAS		DETAILS
M MAXIMUM OUTPUT AIR EXTRACTION (M3/H)		260
M DRAUGHT CAPACITY IN SPEED 2		375
M DRAUGHT CAPACITY IN SPEED 3		650
M DRAUGHT CAPACITY IN SPEED 4		N/A
M CAP. ASP. RECIRCULACION S/N 61591 NIVEL MAX		400
M SOUND POWER SPEED 2		45
M SOUND POWER SPEED 3		56
M SOUND POWER SPEED 4		65
M SOUND POWER S/N 60704-3 SPEED 4		N/A
M REGULATION SOUND POWER S/N 60704-3 MAXIMUM LEVEL		68
04 - ACCESORIES		DETAILS
OPTIONAL ACCESSORIES		NO
M CARBON FILTER (OPTIONAL)		AFC-15
M EXTENSION KIT (OPTIONAL)		ATC-600X
05 - ELECTRICAL CONNECTION		DETAILS
M TOTAL POWER (W)		330
TOTAL POWER OF THE MOTORS (W)		250
M TOTAL POWER OF THE LAMPS (W)		80
VOLTAGE/ FREQUENCE (V/HZ)		220-240V/50Hz
CURRENT (A)		10
06 - LOGISTICS DATAS		DETAILS
DIMENSIONS (H x W x D) (MM)		143 x 999 x 700
CHIMNEY REGULATION DIMENSIONS MAX-MIN (MM)		692 MM / 1052 MM
NET WEIGHT (KG)		28.65