

HOODS - FAGOR
 932011877
3CC-239EX

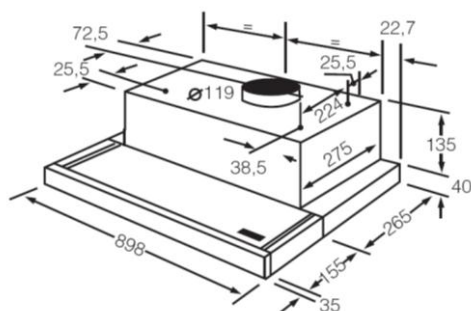

01 - GENERAL DESCRIPTION		DETAILS
M	TYPE	TELESCOPIC
M	INSTALATION	UNDER FORNITURE
M	DOUBLE TURBINE MOTOR	NO
M	ASPIRACION PERIMETRAL	NO
M	MOTOR LOCATION	INTEGRATED
M	NUMBER OF SPEED SETTINGS	3
M	BOOST POSITION	NO
M	CONTROL PANEL	SLIDER
M	TYPE OF LAMPS	INCANDESCENT LIGHT
M	EVACUATION MODE	YES
M	RECYCLING MODE	YES (CONVERTIBLE)
M	MINIMUM DISTANCE FROM GAS HOBS (MM)	650
M	MINIMUM DISTANCE FROM ELECTRIC HOBS (MM)	550
M	EASY TO CLEAN INTERNAL DESIGN	NO
M	O2 PURIFICATION	NO
02 - STANDARD EQUIPMENT		DETAILS
M	TYPE OF CONTROL	MECHANIC
M	DISPLAY LCD	NO
M	SPEED DISPLAY	NO
M	AUTOMATIC MOTOR SWITCH OFF	YES
M	NUMBER OF LAMPS	2
M	GREASE FILTER MATERIAL	MODULAR METALIC FILTER
M	NUMBER OF FILTERS	2
M	NO-RETURN AIRFLOW FLAP	YES
M	FILTER SATURATION SIGNALING	NO
M	AUTOMATIC OPERATION SENSOR	NO
03 - TECHNICAL DATAS		DETAILS
M	MAXIMUM OUTPUT AIR EXTRACTION (M3/H)	240 M3/H
M	DRAUGHT CAPACITY IN SPEED 2	330
M	DRAUGHT CAPACITY IN SPEED 3	400
M	DRAUGHT CAPACITY IN SPEED 4	N/A
M	REGULATION DRAUGHT CAPACITY S/N 61591 MAXIMUM LEVEL	310
M	SOUND POWER SPEED 2	55
M	SOUND POWER SPEED 3	60
M	SOUND POWER SPEED 4	65
M	SOUND POWER S/N 60704-3 SPEED 4	N/A
M	REGULATION SOUND POWER S/N 60704-3 MAXIMUM LEVEL	69
04 - ACCESORIES		DETAILS
M	CARBON FILTER (OPTIONAL)	AFC-150
05 - ELECTRICAL CONNECTION		DETAILS
M	TOTAL POWER (W)	330
M	TOTAL POWER OF THE MOTORS (W)	120
M	TOTAL POWER OF THE LAMPS (W)	80
M	VOLTAGE/ FREQUENCY (V/HZ)	220-240V/50Hz
M	CURRENT (A)	10
06 - LOGISTICS DATAS		DETAILS
M	DIMENSIONS (H x W x D) (MM)	120 x 900 x 300
M	CHIMNEY REGULATION DIMENSIONS MAX-MIN (MM)	794 MM / 1140 MM
M	NET WEIGHT (KG)	8.84