

**HOODS - FAGOR**  
 932013189  
**7CFT-NERO ISL**

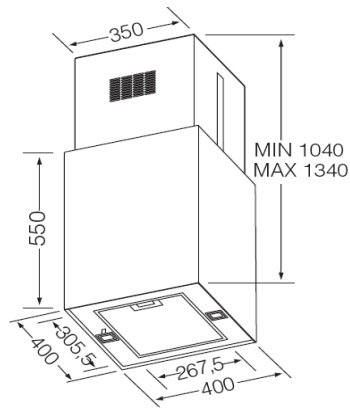

01 - GENERAL DESCRIPTION		DETAILS
	TYPE	DECORATIVE
	INSTALLATION	ISLE
	DOUBLE TURBINE MOTOR	YES
M	ASPIRACION PERIMETRAL	NO
	MOTOR LOCATION	INTEGRATED
	NUMBER OF SPEED SETTINGS	4
	BOOST POSITION	YES
	CONTROL PANEL	TOUCH CONTROL
	TYPE OF LAMPS	HALOGENE LIGHT
	EVACUATION MODE	YES
	RECYCLING MODE	YES (CONVERTIBLE)
	MINIMUM DISTANCE FROM GAS HOBS (MM)	650
	MINIMUM DISTANCE FROM ELECTRIC HOBS (MM)	550
M	EASY TO CLEAN INTERNAL DESIGN	YES
M	O2 PURIFICATION	NO
02 - STANDARD EQUIPMENT		DETAILS
	TYPE OF CONTROL	ELECTRONIC
M	DISPLAY LCD	NO
	SPEED DISPLAY	YES
	AUTOMATIC MOTOR SWITCH OFF	NO
	NUMBER OF LAMPS	2
	GREASE FILTER MATERIAL	MODULAR METALIC FILTER
	NUMBER OF FILTERS	1
	NO-RETURN AIRFLOW FLAP	YES
	FILTER SATURATION SIGNALING	YES
M	AUTOMATIC OPERATION SENSOR	NO
M	ADJUSTABLE LIGHTING INTENSITY	NO
M	INSULATION SYSTEM	NO
03 - TECHNICAL DATAS		DETAILS
M	MAXIMUM OUTPUT AIR EXTRACTION (M3/H)	260
M	DRAUGHT CAPACITY IN SPEED 2	390
M	DRAUGHT CAPACITY IN SPEED 3	520
M	DRAUGHT CAPACITY IN SPEED 4	650
M	CAP. ASP. RECIRCULACION S/N 61591 NIVEL MAX	400
M	SOUND POWER SPEED 2	42
M	SOUND POWER SPEED 3	50
M	SOUND POWER SPEED 4	58
M	SOUND POWER S/N 60704-3 SPEED 4	65
M	REGULATION SOUND POWER S/N 60704-3 MAXIMUM LEVEL	68
04 - ACCESORIES		DETAILS
	OPTIONAL ACCESSORIES	NO
M	CARBON FILTER (OPTIONAL)	AFC-15
M	EXTENSION KIT (OPTIONAL)	ATC-700X
05 - ELECTRICAL CONNECTION		DETAILS
	TOTAL POWER (W)	290
	TOTAL POWER OF THE MOTORS (W)	250
	TOTAL POWER OF THE LAMPS (W)	40
	VOLTAGE/ FREQUENCE (V/HZ)	220-240V/50Hz
	CURRENT (A)	10
06 - LOGISTICS DATAS		DETAILS
	DIMENSIONS (H x W x D) (MM)	530 x 400 x 400
M	CHIMNEY REGULATION DIMENSIONS MAX-MIN (MM)	1000 / 1340
	NET WEIGHT (KG)	34.7