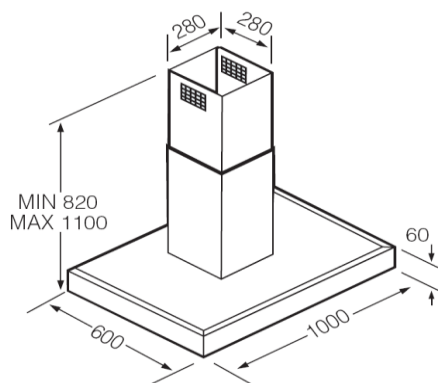

HOODS - FAGOR

932012457

SCFB-100XISLA

01 - GENERAL DESCRIPTION		DETAILS
TYPE		DECORATIVE
INSTALATION		WALL
DOUBLE TURBINE MOTOR		YES
M ASPIRACION PERIMETRAL		NO
MOTOR LOCATION		INTEGRATED
NUMBER OF SPEED SETTINGS		3
BOOST POSITION		YES
CONTROL PANEL		ELECTRONIC TOUCH CONTROL
TYPE OF LAMPS		HALOGENE LIGHT
EVACUATION MODE		YES
RECYCLING MODE		YES (CONVERTIBLE)
M MINIMUM DISTANCE FROM GAS HOBS (MM)		650
M MINIMUM DISTANCE FROM ELECTRIC HOBS (MM)		550
M EASY TO CLEAN INTERNAL DESIGN		YES
02 - STANDARD EQUIPMENT		DETAILS
TYPE OF CONTROL		ELECTRONIC
M SPEED DISPLAY		YES
M AUTOMATIC MOTOR SWITCH OFF		YES
NUMBER OF LAMPS		4
GREASE FILTER MATERIAL		MODULAR METALIC FILTER
NUMBER OF FILTERS		3
NO-RETURN AIRFLOW FLAP		YES
M FILTER SATURATION SIGNALING		YES
M AUTOMATIC OPERATION SENSOR		NO
03 - TECHNICAL DATAS		DETAILS
M MAXIMUM OUTPUT AIR EXTRACTION (M3/H)		240 M3/H
M DRAUGHT CAPACITY IN SPEED 2		375
M DRAUGHT CAPACITY IN SPEED 3		495
M DRAUGHT CAPACITY IN SPEED 4		650
M SOUND POWER SPEED 2		55
M SOUND POWER SPEED 3		62
M SOUND POWER SPEED 4		65
04 - ACCESORIES		DETAILS
M OUTLET REDUCTION KIT (DIAMETER 120 MM)		YES
M CEILING SUPPORT STRUCTURE		YES
05 - ELECTRICAL CONNECTION		DETAILS
TOTAL POWER (W)		260
TOTAL POWER OF THE MOTORS (W)		180
TOTAL POWER OF THE LAMPS (W)		80
VOLTAGE/ FREQUENCE (V/Hz)		230V/50Hz
CURRENT (A)		1.25
06 - LOGISTICS DATAS		DETAILS
DIMENSIONS (H x W x D) (MM)		60 x 1000 x 600
CHIMNEY REGULATION DIMENSIONS MAX-MIN (MM)		820 MM / 1100 MM
M NET WEIGHT (KG)		34.6