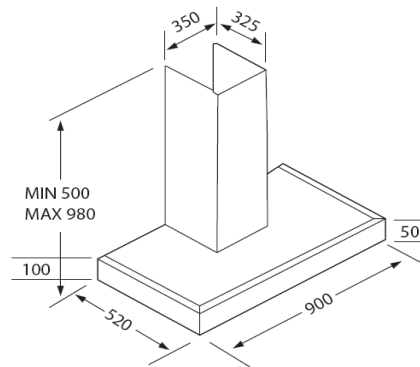

**HOODS - FAGOR**

932010040

**CPT-9 B**

01 - GENERAL DESCRIPTION	DETAILS
TYPE	DECORATIVE
INSTALATION	WALL
DOUBLE TURBINE MOTOR	YES
ASPIRACION PERIMETRAL	NO
MOTOR LOCATION	INTEGRATED
NUMBER OF SPEED SETTINGS	3
BOOST POSITION	NO
CONTROL PANEL	ELECTRONIC BOTTONS
TYPE OF LAMPS	LED
EVACUATION MODE	YES
RECYCLING MODE	YES (CONVERTIBLE)
MINIMUM DISTANCE FROM GAS HOBS (MM)	650
MINIMUM DISTANCE FROM ELECTRIC HOBS (MM)	550
EASY TO CLEAN INTERNAL DESIGN	NO
O2 PURIFICATION	NO
02 - STANDARD EQUIPMENT	DETAILS
TYPE OF CONTROL	ELECTRONIC
DISPLAY LCD	YES
SPEED DISPLAY	NO
AUTOMATIC MOTOR SWITCH OFF	NO
NUMBER OF LAMPS	2
GREASE FILTER MATERIAL	MODULAR METALIC FILTER
NUMBER OF FILTERS	1
NO-RETURN AIRFLOW FLAP	YES
FILTER SATURATION SIGNALING	NO
AUTOMATIC OPERATION SENSOR	NO
ADJUSTABLE LIGHTING INTENSITY	NO
INSULATION SYSTEM	NO
03 - TECHNICAL DATAS	DETAILS
MAXIMUM OUTPUT AIR EXTRACTION (M3/H)	600 M3/H
DRAUGHT CAPACITY IN SPEED 2	800
DRAUGHT CAPACITY IN SPEED 3	950
REGULATION SOUND POWER S/N 61591 MAXIMUM LEVEL	1100
SOUND POWER SPEED 2	49
SOUND POWER SPEED 3	55
SOUND POWER SPEED 4	58
04 - ELECTRICAL CONNECTION	DETAILS
TOTAL POWER (W)	221
TOTAL POWER OF THE MOTORS (W)	215
TOTAL POWER OF THE LAMPS (W)	6
VOLTAGE/ FREQUENCE (V/HZ)	220V/50HZ
CURRENT (A)	1,0
05 - LOGISTICS DATAS	DETAILS
DIMENSIONS (H x W x D) (MM)	80 x 900 x 520
CHIMNEY REGULATION DIMENSIONS MAX-MIN (MM)	520 / 980
NET WEIGHT (KG)	22