

• Safety Guidelines	46
• Environmental Protection	46
• Description of Your Appliance	47
1 / INSTALLING YOUR APPLIANCE	
• Proper positioning	48
• Building in	48
• Hook-up	49
2 / USING YOUR APPLIANCE	
• Description of the top	50
• Cookware for induction	51
• Which cooking zone should you use based on your cookware?	51
• Description of control panel	52
• Powering on	52
• Adjusting the power	52
• Setting the timers	52
• Using the "child safety device"	52
• Safeties during operation	53
3 / DAILY CARE OF YOUR APPLIANCE	
• Protecting your appliance	54
• Maintaining your appliance	54
4 / SPECIAL MESSAGES, DIFFICULTIES	
• During initial use	55
• When powering on	55
• During operation	55
5 / COOKING CHART	
• Cooking chart for food types	56
6 / AFTER-SALES SERVICE	57

As part of our commitment to constantly improving our products, we reserve the right to make changes to them based on technological advances to their technical, functional and/or aesthetic properties.



Attention

Before installing and using your appliance, please carefully read this Guide to Installation and Use, which will allow you to quickly familiarise yourself with its operation.

• SAFETY GUIDELINES

We have designed this cooking hob for use by private persons in their homes.

These cooking hobs are meant to be used exclusively for cooking beverages and foodstuffs and do not contain any asbestos-based materials.

• Residual heat

A cooking zone can remain hot for several minutes after use.

An "H" is displayed during this period.

Avoid touching the hot areas during this time.

• Child safety device

Your hob is equipped with a child safety device that locks its operation after use or during cooking (See "Using the Child Safety Device" section).

Do not forget to unlock it before using the hob again.

• For users of pacemakers and active implants

The functioning of the hob conforms to current electromagnetic interference standards and thus is in total compliance with legal requirements (89/336/CEE directives).

In order to avoid interference between your cooking hob and a pacemaker, your pacemaker must be designed and programmed in compliance with the regulations that apply to it.

Consequently, we can only guarantee that our own product is compliant.

With regard to the compliance of the pacemaker or any potential incompatibility, you can obtain information from the manufacturer or your attending physician.



Electrical Danger

Ensure that the power cables of any electrical appliances plugged in close to the hob are not in contact with the cooking zones.

If a crack appears in the glass worktop, immediately disconnect your appliance to avoid the risk of electric shock.

To do this, remove the fuses or use the circuit breaker.

Do not use your hob until you have replaced the glass worktop.

• ENVIRONMENTAL PROTECTION

This appliance's packaging material is recyclable. Help recycle it and protect the environment by dropping it off in the municipal receptacles provided for this purpose.



Your appliance also contains a great amount of recyclable material. It is marked with this label to indicate the used appliances that should not be mixed with other waste. This way, the appliance recycling organised by your manufacturer will be done under the best possible conditions, in compliance with European Directive 2002/96/EC on Waste Electrical and Electronic Equipment. Contact your town hall or your retailer for the used appliance collection points closest to your home.

We thank you doing your part to protect the environment.

• **DESCRIPTION OF YOUR APPLIANCE**

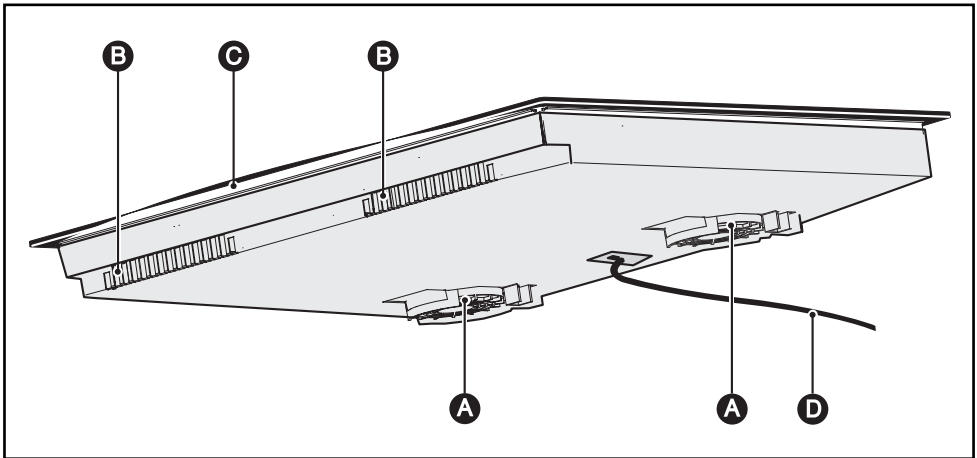

- A** Air intake
- B** Air outlet
- C** Vitroceramic glass
- D** Power cord

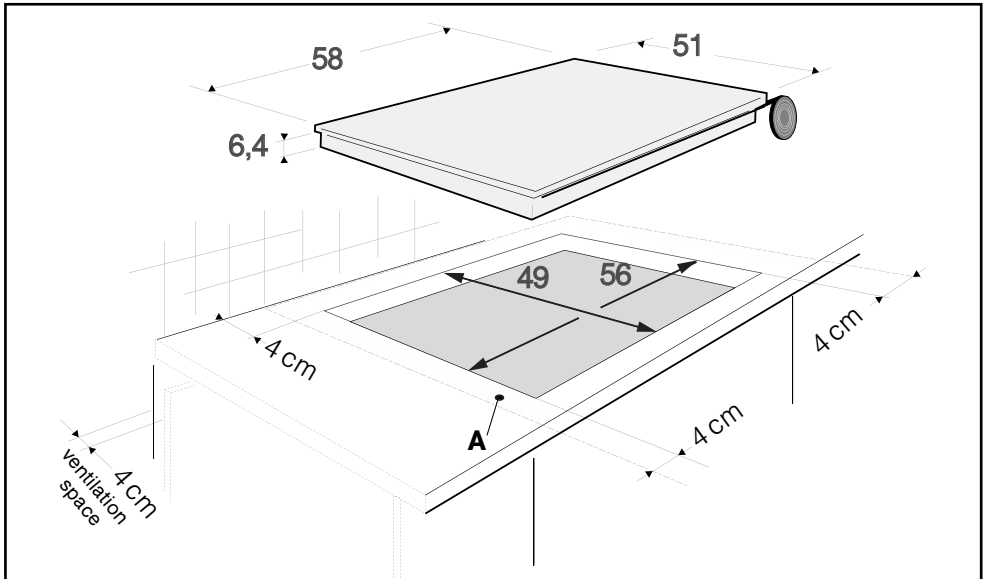

• PROPER POSITIONING

Your appliance should be positioned so that the plug-in unit is accessible.

The distance between the edge of your appliance and the side and rear walls (or partitions) must be at least four centimetres (area A).

Your appliance can be easily integrated above a cabinet, an oven or a build-in-ready household appliance. You must simply ensure that the air intakes and air outlets are clear (See "Description of Your Appliance" section).

• BUILD-IN

Follow the diagram above.

Glue the foam seal underneath your appliance by following the outline of the worktop upon which your appliance will rest. This will allow you to achieve an airtight seal with the worktop.



Tip

If your oven is located below your hob, the hob's thermal safety measures forbid the simultaneous use of the hob and the pyrolysis program of your oven.

Your hob is equipped with an anti-overheating safety device.

This safety can be activated, for example, when the hob is installed over an oven that is not sufficiently insulated. If this occurs, a series of small lines appear in the control panel. In this case, we recommend that you increase the ventilation of your hob by creating an opening in the side of your cabinet



Warning

You must ensure that the air intakes located under your cooking appliance remain clear at all times.

For all types of installation, your induction hob needs proper ventilation.

• HOOK-UP

• 220-240 V monophase hook-up 32- amp fuse.

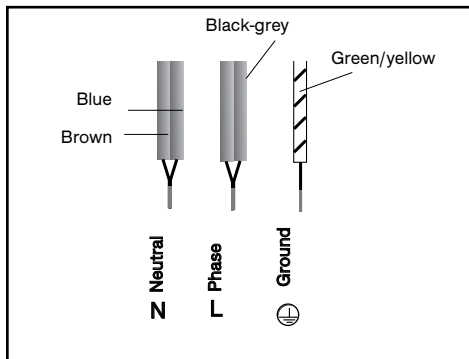

• 400 V 2N triphase hook-up 16-amp fuse.

Separate the two phase wires (L1 and L2) before hooking up.

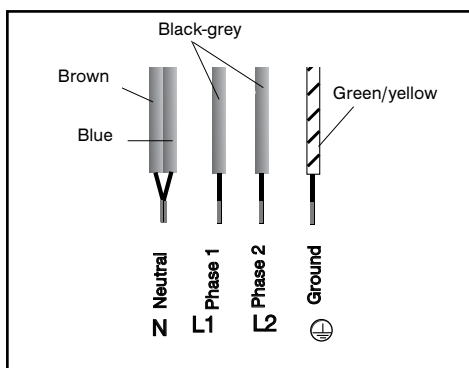

For a 400 V 2N triphase hook-up, if your hob malfunctions, check that the neutral conductor is properly connected.

These hobs must be connected to the power grid via an electrical outlet that complies with EIC publication 60083 or an all-pole cut-off device that complies with installation regulations in effect.

When power is first supplied to your hob, or after an extended power outage, an indicator light will appear on the control panel. It automatically disappears after approximately 30 seconds, or as soon as any touch control on the control panel is pressed. This display is normal and, if needed, serves as an indication to the after-sales service staff. In all cases, the user of the hob should disregard it.



Warning

If the power cable is damaged, it should be replaced by the manufacturer, its after-sales service department or by a person with similar qualifications to avoid danger.

• DESCRIPTION OF THE TOP

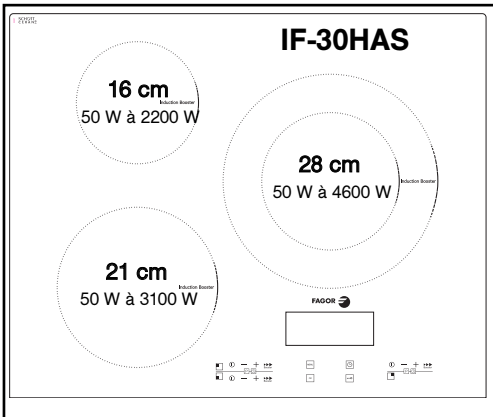
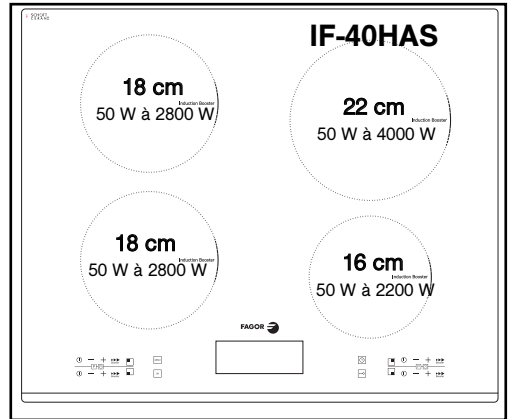
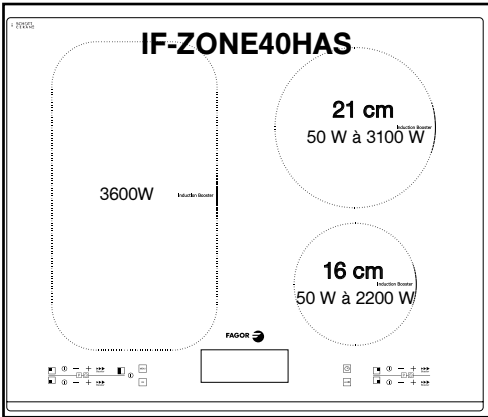
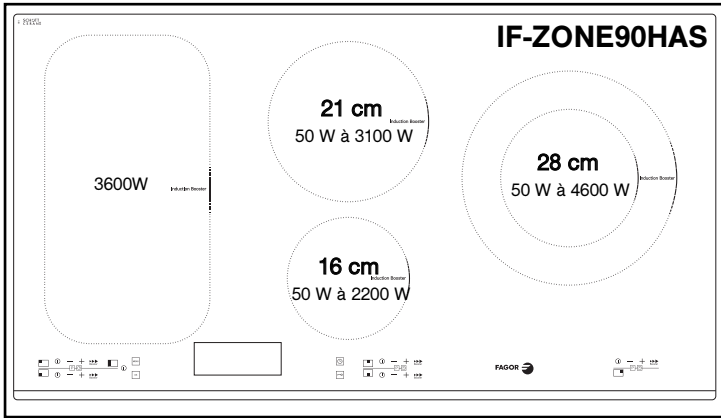

• COOKWARE FOR INDUCTION

• The induction principle

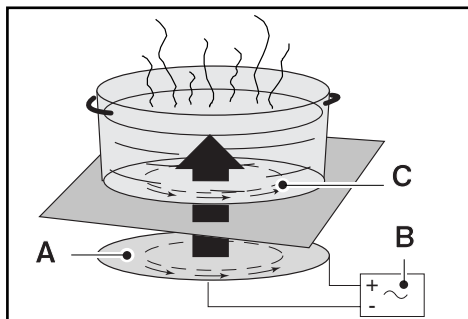

- A** Inductor
- B** Electronic board
- C** Induced electric current

The principle of induction is based on a magnetic phenomenon.

When you place your cookware on a cooking zone and you turn it on, the electronic boards in your cooking hob produce "induced" currents in the bottom of the cookware and instantly raise its temperature. This heat is then transferred to the food, which is simmered or seared depending on your settings.

• Cookware

Most cookware is compatible with induction. Only glass, terra cotta, aluminium without a special finish on the bottom, copper and some non-magnetic stainless steels do not work with induction cooking.

We recommend that you select cookware with a thick, flat bottom. The heat will be distributed better and cooking will be more uniform.

• WHICH COOKING ZONE SHOULD YOU USE BASED ON YOUR COOKWARE?

Cooking zone*	Cookware to use
16 cm	10 18 cm
18 cm	12 22 cm
21 cm	18 24 cm
23 cm	12..... 26 cm
28 cm	12 32 cm

* depending on the model



Tip

To check the suitability of your cookware:

Place the vessel on a cooking zone at power level 4.

If the display remains on, your cookware is compatible.

If the display flashes, your cookware cannot be used with induction cooking.

• PRESENTATION OF THE DISPLAY

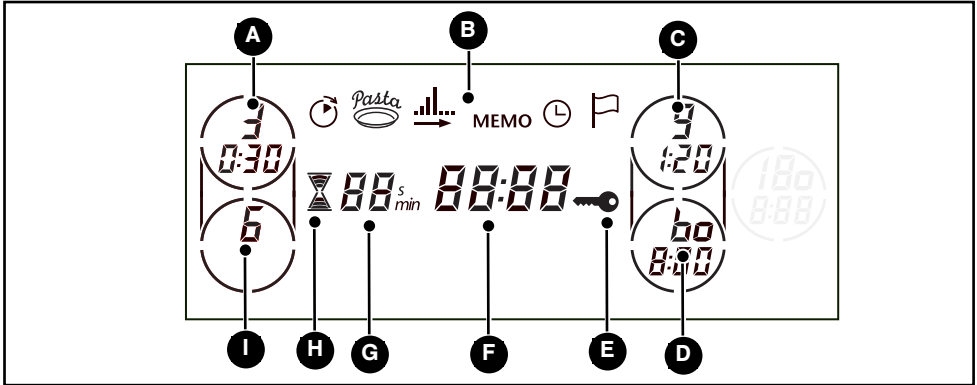

- A** Rear left cooking zone or Evolis display
- B** Function indicator
- C** Rear right cooking zone display
- D** Front right cooking zone display
- E** Control panel lock indicator (child safety device).
- F** Clock display
- G** Independent timer display
- H** Independent timer indicator
- I** Front left cooking zone display

• PRESENTATION OF THE FUNCTION TOUCH CONTROLS

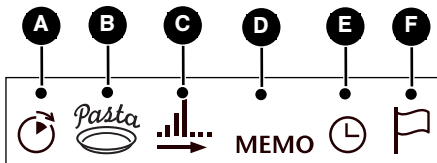

- A** Tempo
- B** Pasta
- C** Total
- D** Memo
- E** Reset time
- F** Language

Text is shown on the display to guide you as you program your settings.

Note: To validate your selection:

- press the **OK** touch control

alternatively, the selection will be automatically validated after a few seconds.

•How select the language

French is the default language displayed.

If you wish to select another language, press the **MENU** touch control until the  indicator flashes.

Select one of the languages proposed:

English OK

Français OK

Espanol OK

Portuguêse OK

Deutsch OK

Confirm by pressing OK.

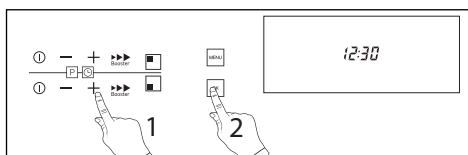
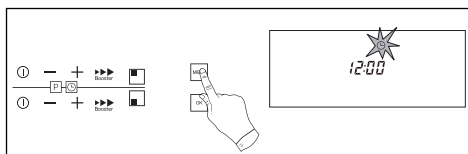

•How to set the time

- When plugged into the electricity supply

The display flashes 12:00.

Set the time by pressing the + or - touch controls on any of the cooking zones (holding your finger on the touch control allows you to scroll through the numbers rapidly).

Example: 12:30

Confirm by pressing OK.

The display stops flashing.

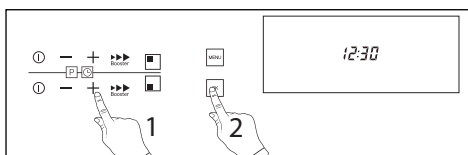
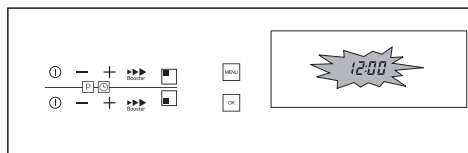

•How to change the time

- To reset the time on the clock

Press the **MENU** touch control until the  indicator flashes

An beep indicates that it is now possible to set the time.

Adjust the time with the + and - touch controls on any of the cooking zones.

Confirm by pressing OK.

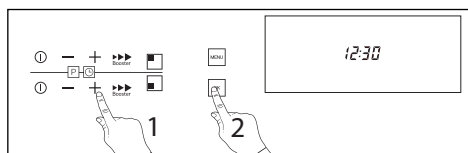
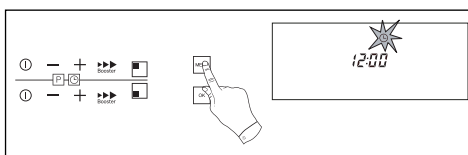

DESCRIPTION OF THE CONTROLS

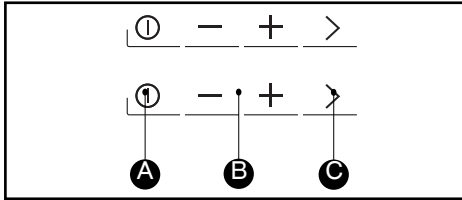

- A** Start/stop touch control.
- B** Power or timer touch controls
- C** Power level preset setting touch controls

OPERATION

Press the start/stop touch control for the cooking zone you want to use. A flashing "0" on the display of the cooking zone selected and a beep indicate that the zone is on. You can then set the power level required using the "-" or "+" touch controls for the cooking zone selected. If you do not select a power level, the cooking zone will automatically shut off after a few seconds.

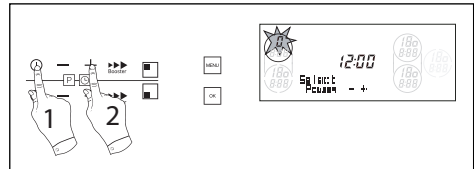

STOP

Press the on/off touch control for the cooking zone selected or reduce the power to zero using the "-" touch control.

ADJUSTING THE POWER LEVEL

Press the power - or + touch controls. When you turn on a cooking zone you can move directly to the power preset settings "bo", 10 and 6 by pressing the > touch control repeatedly.

Adjusting the power preset settings

This function allows you to modify the power levels defined in the preset settings (except for the BOOST).

- Your cooking zone must be turned off.
- Keep your finger on the > touch control.
- 6 and "low - +" are displayed in the text box. Adjust the new power setting by pressing on the - or + touch controls. Confirm by pressing **OK**.

Then 10 "high - +" is displayed in the text box. Adjust and confirm by pressing **OK**.

NB: The preset setting power levels are identical for all the cooking zones:

- press once for 1 and 7
- press twice for 8 and 12.

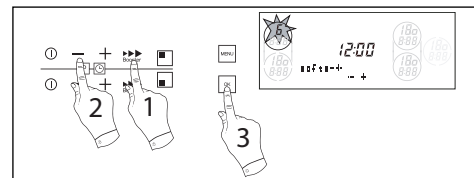

Tip

The zone on the display may go red while the cooking hob is being used. This does not affect operation of the appliance in any way. The display returns to its normal appearance when it is no longer in use.

• TOTAL

This function allows you to program a sequence of 2 different power levels and heating times, for example programming a function to seal the food followed by a second to allow it to simmer.

If you wish to use this function, press on the **MENU** touch control until the  indicator flashes.

- Confirm your selection by pressing **OK**.

A beep indicates that it is now possible to program the settings.

- Select the cooking zone concerned by pressing .

- Adjust the first power level with the **- +** touch controls, then confirm by pressing **OK**.

- Select the cooking time for the first power level with the **- +** touch controls, then confirm by pressing **OK**.

- Select the second power level with the **- +** touch controls, then confirm by pressing **OK**.

- Adjust the second power level with the **- +** touch controls, then confirm by pressing **OK**.

When the last setting has been validated by pressing **OK**, cooking starts using these recorded settings. A beep sounds to indicate that cooking is finished.

NB: This function can only be used on one zone at a time.

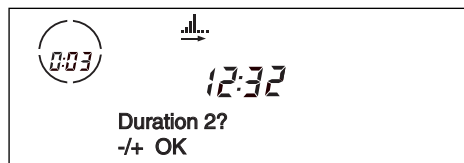
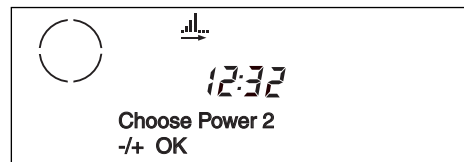
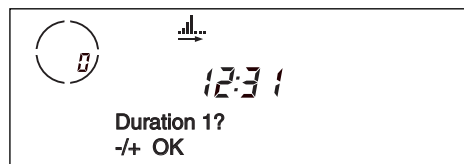
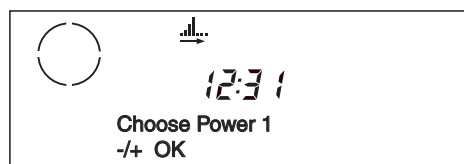
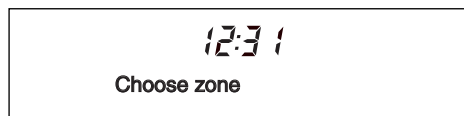
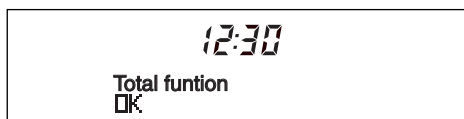

Warning

If you change the settings on a sequence while it is running, the function is automatically cancelled.

Tip

If you are using several receptacles on the hob at the same time, try to use cooking zones located on opposite sides. When you are working on one side of the hob, using the booster on one of the cooking zones automatically limits the power on the other zone visible on the display. This automatic limit also occurs when the pre-heating function is used.

• **SETTING THE TIMERS**

Each cooking zone has its own timer. It can be set as soon as you start cooking.

To turn on or modify the timer, press the  touch control briefly.

0:00 flashes in the last cooking zone selected.

To select the cooking zone desired:

- Press successively on the  touch control until the desired zone is displayed.

0:00 flashes in the desired zone.

- Press on the - or + touch control for the zone in question to adjust the time desired (from 0:01 to 9:59)

When cooking is finished, 0:00 is displayed and a beep sounds. To cancel this information, press any button for the particular cooking zone being used. Otherwise, the information will disappear after a few seconds.

To stop the timer manually, press “-” and “+” at the same time or return to 0 using the “-” touch control.

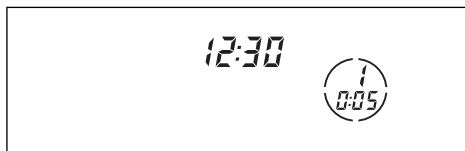

• **INDEPENDENT TIMER**

To access this function, hold down the  touch control.

0 appears on the display and the hourglass flashes. Press the - or + touch controls for any one of the cooking zones. You can adjust your independent timer between 01 and 99 minutes.



• TEMPO

This function displays the time elapsed since the last power setting adjustment was made on all of the zones that are in use.

To use this function, press and hold the **MENU** touch control until the  indicator flashes.

The time elapsed appears in the display.

Note: If a time is displayed on the timer, this time cannot be modified until 5 seconds later. After these 5 seconds have elapsed, you can modify your cooking time.

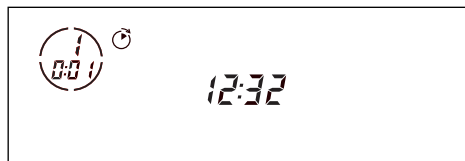
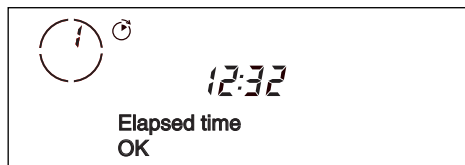



• PASTA

This function allows you to boil water and to maintain it at its boiling point if you wish to cook pasta, for example.

Press the **MENU** touch control until the  indicator starts to flash.

- Confirm by pressing **OK**.

- The  indicator remains displayed, without flashing. A beep is emitted.

- Select the desired zone by pressing on  .

- Press the **-/+** touch control to indicate the amount of water. (from 0.5 to 6 litres).

- Confirm by pressing **OK**.

Cooking starts.

A beep is emitted when the water begins to boil.

- Add the pasta.

- Confirm by pressing **OK** then indicate the cooking time using your timer.

A beep sounds to indicate that cooking is finished.

NB: It is important that the water temperature is neither too hot nor too cold when cooking begins otherwise the final result will be affected.

Do not use cast iron cookware.

This function can only be used on one zone at a time.

You can use this function to cook any other food that is cooked in boiling water.

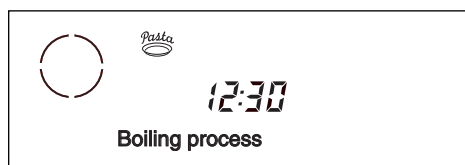
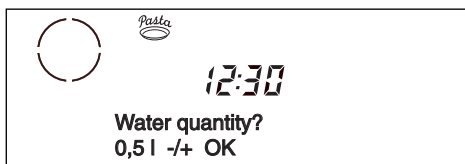
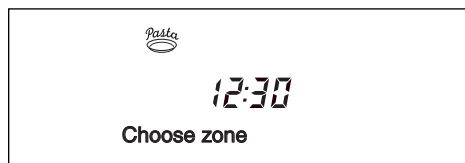



LOCKING 

This function allows you to lock the control panel when it is turned off (for cleaning for example) or during cooking (to ensure that your settings are not changed).

For safety reasons, only the “stop” buttons are always active allowing the heating zone to be turned off even if locked.

To lock:

Press the  touch control until the  indicator flashes.

A beep will confirm your action.

Keep your finger on the  touch control until the key appears in the display.

To unlock:

Keep your finger on the  touch control until the key is no longer displayed.

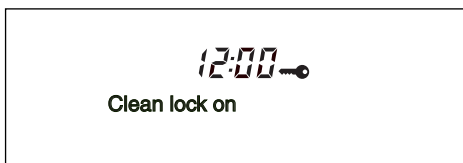
**CLEAN LOCK** 

This function allows you to temporarily lock your hob while cleaning.

To activate Clean lock:

- Your cooking hob must be turned off.
- Briefly press the  touch control. A beep sounds.
- After a predefined time, the lock will be automatically cancelled. A double beep is emitted.

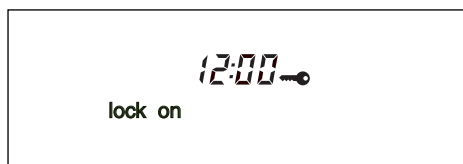

MEMO MEMO

This function allows the hob to memorise and reproduce an entire cooking cycle.

To memorise settings:

- Press the **MENU** touch control until the MEMO indicator starts to flash.
- Confirm, the indicator stops flashing.
- Select the cooking zone by pressing ① .

- “Memorise -/+” appears in the screen.

- Confirm by pressing **OK**, then “Record your cooking settings” appears, select a power level using the -/+ touch controls. Each change in power level and cooking time is recorded.

When “Memo end” appears, it is no longer possible to record new cooking levels.

To use settings:

“Memorise -/+” appears in the display, press on the -/+ touch controls until “Use -/+” appears

- Confirm by pressing **OK**.

Cooking starts using the levels recorded.

NB:

-5 different power levels can be memorised per cooking zone.

-In order to accurately reproduce the memorised cycle, we recommend that you always use the same cookware.

Levels lasting less than 10 seconds cannot be memorised.

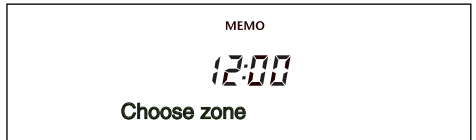

• SAFETY DURING OPERATION

• Residual heat

After intensive use, the cooking zone that you have just used can remain hot for several minutes.

An "H" is displayed during this period.

Avoid touching the hot areas during this time.

• Temperature limiter

Each cooking zone is equipped with a safety sensor that constantly monitors the temperature of the bottom of the cookware. In the event that an empty vessel is left on a cooking zone that is on, this sensor automatically adjusts the power output of the hob, thereby avoiding any risk of damage to the cookware or the hob.

• "Small Items" safety

A small object (such as a fork, a spoon, a ring, etc.) left alone on the hob is not detected as a piece of cookware.

The display flashes and no heat is produced.



Warning

Several small objects together on a cooking zone may be detected as cookware.

If the display remains on: power may be supplied and the objects may be heated.

• Protection against overflows

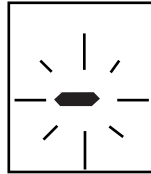

The hob may shut down (with the adjacent symbol in the display) automatically in any of these three situations:

- Overflow that spills onto the touch controls.
- Damp towel placed over the touch controls.
- Metallic object placed on the touch controls.

Clean the hob or remove the object, then begin cooking again.

• Auto-Stop system

If you forget to turn off a cooking zone, your hob is equipped with an "Auto-Stop system" safety measure that will automatically shut off the forgotten cooking zone after an amount of time pre-set at the factory (see the table below).

Power level used	The cooking zone automatically shuts off after
between 1 and 4	8 hours
between 5 and 7	2 hours
for 8 and 9	1 hour

In the event that this safety measure is triggered, the powering off of the cooking zone is indicated by an "A" displayed in the control panel. Simply pressing on any of the touch controls will cancel this display.

• PROTECTING YOUR APPLIANCE

Avoid hard shocks from cookware:

The vitroceramic glass worktop is very sturdy; however, it is not unbreakable.

Do not place any hot lids flat on your cooking hob. A suction effect may damage the vitroceramic surface.

Avoid dragging cookware across the surface, which may in the long-term result in the degradation of the decorative finish of the vitroceramic top.

Avoid placing cookware on the frame or cover (depending on the model).

Avoid using cookware with rough or bumpy bottoms: they can capture and transfer particles that may produce stains or scratches on your hob.

These defects that do not result in appliance malfunction or do not make it unsuitable for use are not covered by the warranty.

• MAINTAINING YOUR APPLIANCE

Do not store cleaning products or flammable products in the cabinet underneath your cooking hob.

Do not heat unopened canned goods; they may burst.

Of course, this precaution applies to all types of cooking.

Never use a sheet of aluminium for cooking. Never place items wrapped in aluminium foil or packaged in aluminium dishes on your cooking hob.

The aluminium will melt and permanently damage your cooking appliance.

Objects not intended for cooking should never be placed on the hob (risk of powering on, scratches, etc.).

Steam cleaning should never be used. The steam jet could damage your hob.

TYPE OF STAINS/SPOTS	USE	WHAT TO DO
Light.	Disinfectant sponges.	Thoroughly moisten the zone to be cleaned with hot water, then wipe off.
Accumulation of baked-on soil. Overflow of sugary preparations, melted plastic.	Disinfectant sponges. Scraper for glass.	Thoroughly moisten the zone to be cleaned with hot water. Use a scraper for glass to remove the large bits, follow with the rough side of a disinfectant sponge, and then wipe off.
Rings and hard water residue.	White spirit vinegar.	Apply warm white vinegar to the stain, let stand, then wipe with a soft cloth.
Shiny metallic streaks. Weekly maintenance.	Cleaning agent for vitroceramic glass.	Apply a cleaning agent for vitroceramic glass (preferable one with silicone for its protective properties) to the surface.



Cream



Special disinfectant sponge for delicate dishes



Powder



Scouring sponge



• During initial use

<i>YOU OBSERVE THAT:</i>	<i>POSSIBLE CAUSES:</i>	<i>WHAT SHOULD YOU DO:</i>
An indicator light appears.	Working normally.	Nothing.
Your installation blows a fuse.	The electrical hook-up of your hob is incorrect.	Verify the connections. See the "Hook-Up" section.
Only one side works.		
The hob produces an odour during the first cooking sessions.	New appliance.	Operate each cooking zone for 30 minutes with a saucepan full of water.

• When powering on

<i>YOU OBSERVE THAT:</i>	<i>POSSIBLE CAUSES:</i>	<i>WHAT SHOULD YOU DO:</i>
The hob is not working and the indicator lights on the control panel are not on.	The appliance is not receiving electricity. The electrical supply is defective or the hook-up is incorrect.	Inspect the electrical circuit breaker and fuses.
The table is not working and another message is displayed.	The electronic board is functioning poorly.	Call the After-Sales Service Department.

• During operation

<i>YOU OBSERVE THAT:</i>	<i>POSSIBLE CAUSES:</i>	<i>WHAT SHOULD YOU DO:</i>
The hob stops working and it emits a beep approximately every 10 seconds and a  or "F7" is displayed.	There was an overflow or an object is in contact with the control panel.	Clean the hob or remove the object, then begin cooking again.
A series of small  or "F7" is displayed.	The electronic boards heated up.	See "Built-In" section.
After turning on a heating zone, the indicator lights on the control panel continue to flash.	The cookware used is not suitable for induction or is less than 12 cm in diameter (10 cm for the 16-cm cooking zone).	See section on cookware for induction.
The saucepans make noise during cooking. Your hob makes a clicking sound during cooking.	This is normal with some types of cookware. This is caused by the transfer of energy from the hob to the cookware.	Nothing. There is no risk, neither to your hob nor to your cookware.
The fan continues to function a few minutes after your hob is turned off.	Cooling of the electronic components. Working normally.	Nothing.



Warning

In the event that there is a break, crack or opening—even minor—in the vitroc ceramic glass, immediately disconnect your appliance to avoid the risk of electric shock. Contact the After-Sales Service Department.

• COOKING CHART

		FRY BRING TO A BOIL		COOK/BROWN RETURN TO BOILING BOILING LIGHT BROTHS		COOK/SIMMER			KEEP WARM	
		9	8	7	6	5	4	3	2	1
SOUPS	BROTHS						●			
	THICK SOUPS								●	
FISH	COURT BOUILLON				●					
	FROZEN FOODS					●				
SAUCE	THICK, FLOUR-BASED						●			
	BUTTER-BASED WITH EGGS (BEARNAISE, HOLLANDAISE)						●			
	PREPARED SAUCES	9	8	7	6	5	4	3	2	1
VEGETABLES	ENDIVES, SPINACH								●	
	DRIED BEANS								●	
	BOILED POTATOES					●				
	GOLDEN BROWN POTATOES					●				
	SAUTEED POTATOES					●				
	DEFROSTING VEGETABLES								●	
MEAT	MEAT, NOT TOO THICK			●						
	STEAKS, IN SKILLET				●					
	GRILLED MEATS (CAST IRON GRILL)			●						
FRYING	FROZEN FRENCH FRIES	●								
	FRESH FRENCH FRIES	●								
		9	8	7	6	5	4	3	2	1
MISCELLANEOUS	PRESSURE COOKER (ONCE IT STARTS WHISTLING)						●			
	COMPOTES					●				
	CRÊPES				●					
	CRÈME ANGLAISE			●						
	MELTED CHOCOLATE									●
	JAMS					●				
	MILK			●						
	EGGS, FRIED				●					
	PASTA				●					
	JARS OF BABY FOOD (DOUBLE BOILER)					●				
	MEAT STEW			●						
	SPANISH RICE								●	
	RICE PUDDING								●	

In the unlikely event of there being a problem with your appliances please call the number below quoting the model number of your appliance - this can be found on the rating plate. Our trained staff are available to advise or book a service call with one of our authorized service agents.

Enquiries for :

- for in-warranty service – telephone **0870-060-3230**
- for contact details of local repair agents for out-of-warranty service – telephone **0870-060-3230**
- to buy replacement spare parts – telephone **0870-443-1899**.
- for extended warranty (and for all other general and promotion information)
– **www.fagor.com/uk**

CZ5700055 / 00 12/09