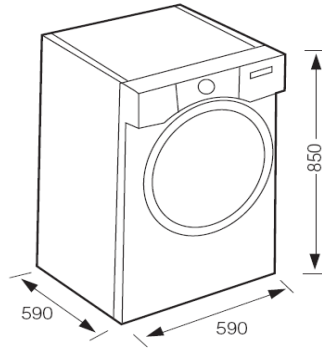

WASHING MACHINE - FAGOR

905014692

F-4812

01 - TYPE		DETAILS
M	HEIGHT WITHOUT WORKTOP (MM)	820 MM
M	TUB MATERIAL	POLYPROPYLENE
M	DRUM MATERIAL	STAINLESS STEEL
M	DRUM VOLUME (L)	56 L
M	HATCH DOOR OPENING 180°	YES
M	HATCH DOOR DIAMETER	34
M	COVER DOOR / DOUBLE DOOR	NO
M	DOOR HINGE	RIGTH
M	FILTER SYSTEM	ACCESSIBLE
02 - GENERAL		DETAILS
M	ACOUSTIC INSULATION TYPE	BASE
M	ANTI-FLOODING SAFETY	YES
M	FOAM CONTROL	YES
M	INSTANTANEOUS DOOR OPENING	YES
M	LIQUID DETERGENT POSSIBILITY	YES
M	NUMBER OF WASHING PRODUCT INLETS	3
M	OPENING SAFETY DOOR / LID	YES
M	ABS SYSTEM	YES
M	SELF ADJUSTING WATER LEVEL TO LOAD	YES
M	WASH OPTIMIZATION	WATER RECIRCULATION
M	WATER PLUS	NO
M	WHEELS	NO
03 - PROGRAMMING		DETAILS
M	HOT & COLD WATER INTAKE?	NO
M	FREQUENCY (HZ)	50 HZ
M	VOLTAGE (V)	220-240 V
M	CURRENT (A)	10 A
M	CONNECTION RATING (W)	2200 W
M	TOTAL NUMBER OF PROGRAMMES	16
M	DELICATES / SILK	YES
M	FAST PROGRAM	15 MIN. Y 30 MIN.
M	STANDARD PROGRAM (COTTON)	YES
M	COLD WASH OPTION	YES
M	WOOL PROGRAM	YES
M	MIXED PROGRAMME	YES
M	PROG. DUVET	YES
M	PROG. CURTAINS	YES
M	PROG. ANTIBACTERIAS/HYGIENE	YES
M	PROG. STUBBORN STAINS	YES
04 - OPERATING CONTROL		DETAILS
M	SINGLE KNOB TYPE (PROGRAMME-TEMPERATURE CONTROL)	RETRACTABLE INNOVATION
M	DRYING TIME SELECTION CONTROL	NO
M	LCD VISUALISATION SCREEN	YES
M	PROGRESS INDICATOR	LCD DISPLAY
M	DIGITAL INDICATOR TIMING/COUNTDOWN SETTING	YES
M	START DELAY OPTIONS	24
M	INTENSIVE WASH KEY	YES
M	EASY IRONING KEY	YES
M	EXTRA RINSE KEY	YES
M	HALF LOAD OPTION	NO
M	ON/OFF KEY	YES
M	ON/OFF KEY	YES
M	RINSE HOLD	YES
M	SELECTION LOCKING KEY	YES
05 - SPIN SPEED OPTIONS		DETAILS
M	SKIP SPIN	YES
M	SPIN SPEED OPTIONS	0.400 A MAX.(DE 100 EN 100)
06 - ENERGY LABELLING		DETAILS
M	MAXIMUM SPIN SPEED (RPM)	1200
M	CAPACITY COTTON (KG)	8.0
M	ENERGY EFFICIENCY CLASS	A+++
M	SPIN DRYING PERFORMANCE CLASS	B
M	NOISE LEVEL SPINNING (DB(A) RE 1 PW)	57
M	NOISE LEVEL SPINNING (DB(A) RE 1 PW)	77
M	TOTAL ANNUAL ENERGY CONSUMPTION (KWH)	196 KWH
M	TOTAL ANNUAL WATER CONSUMPTION (L)	11000 L
M	MOISTURE CONTENT % ON DRY LOAD AFTER MAXIMUM SPIN	53 %
07-TECHNICAL SPECIFICATIONS		DETAILS
M	WASH ENERGY CONSUMPTION (KWH)	0.99 KWH
M	ENERGY CONSUMPTION FOR COTTON 60°C	0.85 KWH
M	ENERGY CONSUMPTION FOR COTTON 40°C	0.70 KWH
M	TOTAL INSTALLED POWER (OFF-MODE) (W)	< 1W
M	TOTAL INSTALLED POWER (LEFT-MODE) (W)	< 1W
M	DURATION FOR COMPLETION OF 60°C FULL LOAD COTTON	177 MIN
M	DURATION FOR COMPLETION OF 40°C FULL LOAD COTTON	174 MIN
M	DURATION LEFT-MODE	20 MIN
08- LOGISTIC DATAS		DETAILS
M	DIMENSIONS WITH WORKTOP (H x W x D) (MM)	850 x 590 x 590