

INSTALLATION AND USERS MANUAL

Oven

MANUAL DE INSTALACIÓN Y DE UTILIZACION

Horno

MANUAL DE INSTALAÇÃO E DO UTILIZADOR

Forno

MANUEL D'INSTALLATION ET D'UTILISATEUR

Four

INSTALLATIONS- UND BEDIENUNGSANLEITUNGEN

Backofen

EINBAU- UND BETRIEBSANLEITUNG

Backofen

NÁVOD NA INSTALACI A POUŽITÍ

Trouba



1 / INFORMATION FOR THE USER	
• Steam cooking _____	04
• Safety instructions _____	05
• Care for the environment _____	06
2 / INSTALLING YOUR APPLIANCE	
• Choice of location _____	07
• Fitting _____	07
• Electric connection _____	08
3 / DESCRIPTION OF YOUR APPLIANCE	
• Operating principle _____	09
• Introduction to your oven _____	09
• Accessories _____	10
• Introduction to the programmer _____	11
4 / USING YOUR APPLIANCE	
• How to set the time _____	12
• Cooking times programmed for different functions _____	12
• Instant steam cooking _____	13
• Cancelling cooking in progress _____	14
• At the end of a cooking programme _____	14
• Water management _____	14
• Delayed cooking _____	15
• Using the timer function _____	16
• Control panel locking (child safety device) _____	16
• Display stand-by mode _____	17
5 / FUNCTION DESCRIPTION AND COOKING CHART _____	18
• Oven cooking modes _____	19-20
6 / CARING FOR AND CLEANING YOUR APPLIANCE	
• Cleaning the outer surfaces _____	21
• Cleaning the cavity _____	21
• Cleaning the water intake tube _____	21
• Cleaning the steam generator _____	21
7 / TROUBLESHOOTING _____	22
• Changing the bulb _____	23
8 / AFTER-SALES SERVICE	
• Repairs _____	24

• **STEAM COOKING**

Overview

Steam cooking presents nothing but advantages if you follow the instructions for use. Healthy and natural, steam cooking preserves the full flavour of foods. A delicate sauce or aromatic herb seasonings add that something extra that makes the difference.

This kind of cooking releases no odours. There is no need to season the cooking water with herbs or spices; however, you can flavour a fish by placing it on a bed of seaweed or make a savoury poultry dish by adding a bunch of rosemary or tarragon.

You can simultaneously cook meat, fish and vegetables.

Steam cooking gently reheats pasta, rice and mashed potatoes with no risk of food sticking or drying out.

It facilitates cooking custard creams and tarts, rice pudding... covered with aluminium foil, the condensation water does not add moisture to the preparations.

There is no need to season before cooking, not even the steam water.

To make meat look more appetising, quickly brown it on all sides with hot butter in a pan.

Compared to boiling, steam offers nothing but advantages:

It is quick: cooking starts immediately whereas for food in a water-filled dish, the cook time only begins counting down once the water returns to a full boil.

It is healthy: vitamins (those that are water soluble) and minerals are well preserved because they scarcely dissolve in the condensation water that touches the food.

Moreover, no fats are used for this type of cooking.

The steam maintains the taste of food. It does not add odours, nor the taste of the grill or the pan. Furthermore, it takes nothing away because the food is not diluted in the water.

Words of advice: there is no point in using this cooking method to prepare fish that is not fresh or vegetables left in the refrigerator for a week: the results will be catastrophic!

therefore do not hesitate to save both time and money by cooking items side by side, but without touching. For example, you can cook a fish next to a dessert.

Steam is also appropriate for blanching, defrosting and reheating or even holding warm, especially sauces.

First use a very small amount of fat to heat meats like poultry, veal and pork so that they take on an appetizing browned appearance. Then finish cooking them using the steam method.

Cut into pieces, food cooks faster and more evenly than if left whole.

**Warning**

Keep this user guide with your appliance. If the appliance is ever sold or transferred to another person, ensure that the new owner receives the user guide. Please become familiar with these recommendations before installing and using your oven. They were written for your safety and the safety of others.

• SAFETY INSTRUCTIONS

- This oven was designed for use by private persons in their homes. It is intended solely for cooking foodstuffs. This oven does not contain any asbestos-based components.
- This appliance is not intended for use by people with (including children) impaired physical, sensorial or mental abilities, or people lacking in knowledge or experience, unless they receive prior supervision or instructions on using the appliances through a person responsible for their safety.
- When you receive the appliance, unpack it or have it unpacked immediately. Give it an overall inspection. Make note of any concerns or reservations on the delivery slip and make sure to keep a copy of this form.
- Your appliance is intended for standard household use. Do not use it for commercial or industrial purposes or for any other purpose than that for which it was designed.
- Do not modify or attempt to modify any of the characteristics of this appliance. This would be dangerous to your safety.
- Keep young children away from the appliance while it is in operation. In this way you will avoid the danger of them being burned by knocking over cooking recipients.
- Never pull your appliance by the door handle.
- During cooking, ensure that the door of your oven is completely closed so that the seal can do its job properly.
- Please make sure children do not play with the appliance.
- When in use, the appliance becomes hot. Do not touch the heating elements located inside the oven. In doing so, you would run the risk of suffering serious burns.
- When placing dishes inside or removing them from the oven, use heat-protective kitchen gloves.
- At the end of cooking, do not touch the dishes with bare hands.
- Do not place heavy weights on the open oven door, and make sure that children are able neither to climb nor sit on it.
- The oven must be turned off when cleaning inside the oven.
- Intensive and prolonged use of the appliance may give rise to the need for additional ventilation, by opening a window, or by increasing the power of the mechanical fan.
- Additionally to the accessories supplied with your oven, only use dishes which resist high temperatures (follow the manufacturer's instructions).
- After using your oven, make sure that all the controls are in their stop position.
- Never use steam or high-pressure devices to clean the oven (requirement imposed by electrical safety concerns).

• CARE FOR THE ENVIRONMENT

– This appliance's packing materials are recyclable. Recycle them and play a role in protecting the environment by depositing them in municipal containers provided for this purpose.

– Your appliance also contains many recyclable materials. It is therefore marked with this logo to indicate that used appliances must not be mixed with other waste. Recycling of the appliances organised by your manufacturer will thus be undertaken in optimum conditions, in accordance with European directive EC/2002/96 relating to electrical and electronic equipment waste. Consult your city hall or your retailer to find the drop-off points for used appliances that is nearest to your home.



– We thank you for your help in protecting the environment.



Warning

Installation should only be performed by installers and qualified technicians.

This appliance complies with the following European directives:

- Low Voltage Directive EEC/73/23 modified by directive EEC/93/68 for insertion of EC marking.

- Electromagnetic Compatibility Directive 89/336/EEC modified by directive 93/68/EEC for insertion of EC marking.

- EC regulation no. 1935/2004 concerning materials and objects intended for contact with food substances.

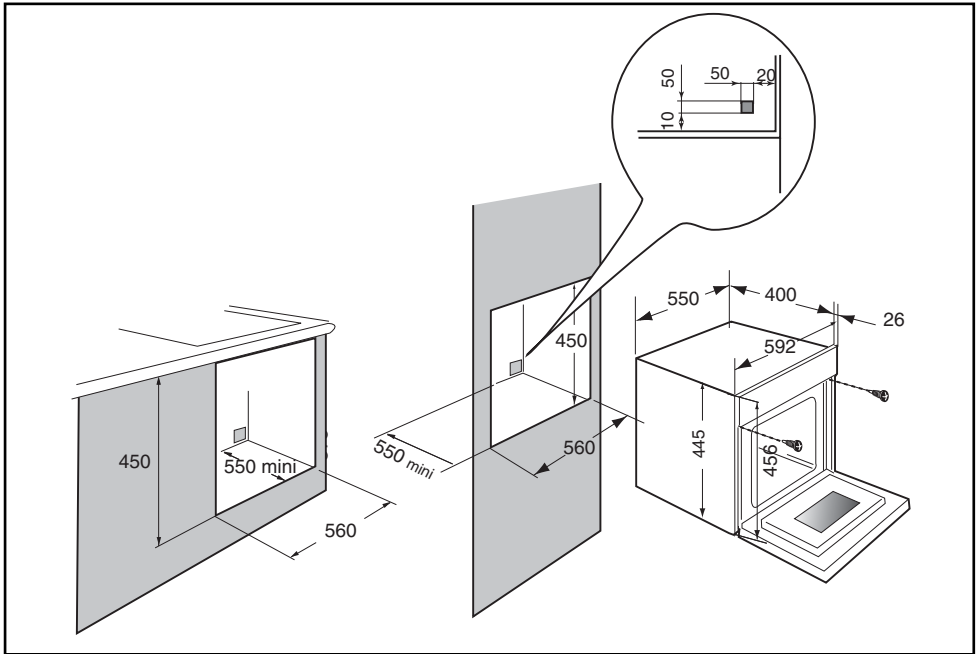

• CHOICE OF LOCATION

The diagrams above determine the dimensions of a cabinet that will be able to hold your oven.

The oven may be installed either under a worktop or in a column of cabinetry (open or closed) that has the appropriate dimensions for built-in installation.

- For greater stability, attach the oven in the cabinet with 2 screws through the holes provided for this purpose on either side of the front inner panel.

• FITTING

To do this:

- 1) Drill a $\varnothing 2$ mm hole in the cabinet panel to avoid splitting the wood.
- 2) Attach the oven with the two screws.



Tip

To be certain that you have properly installed your appliance, do not hesitate to seek advice from a household appliance specialist.



Warning

We cannot be held responsible for any accident or incident resulting from non-existent, defective or incorrect earthing.

If the electrical installation in your residence requires any changes in order to hook up your appliance, call upon a professional electrician.

If the oven malfunctions in any way, unplug the appliance or remove the fuse corresponding to the sector where the oven is hooked up.

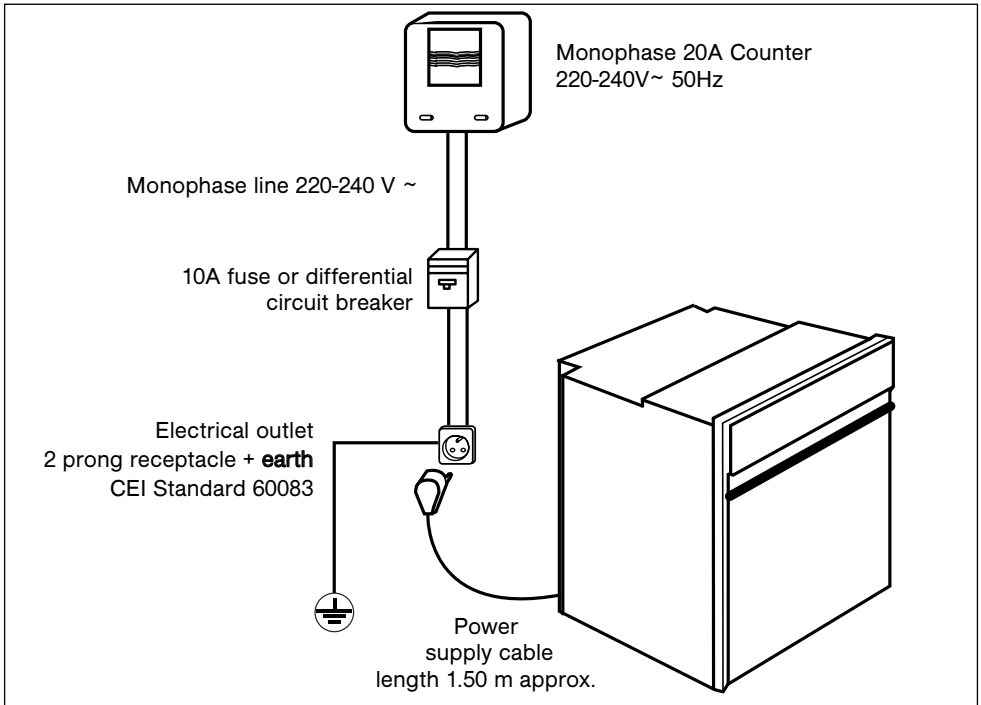

• ELECTRIC CONNECTION

Electrical safety must be provided by a correct build-in. During fitting and maintenance operations, the appliance must be unplugged from the electrical grid; fuses must be switched off or removed.

The electrical connection should be performed before the appliance is installed in the cabinet.

Ensure that:

- the electrical installation has sufficient voltage,
- the electrical wires are in good condition
- the diameter of the wires complies with the installation requirements.

Your oven must be connected with a (standardised) power cable with 3 conductors of 1.5mm² (1 live + 1 neutral + earth) which must be connected to a

220-240V ~single-phase grid via the intermediary of a 1 live + 1 neutral + earth CEI 60083 standardised power socket or via an all-pole cut-off device in compliance with the installation rules.



Warning

The safety wire (green-yellow) is connected to the appliance's terminal  and must be connected to the ground lead of the electrical set-up. In the case of connection to an electric wall socket, it must remain accessible after installation.

The fuse in your set-up must be 10 amperes. If the power cable is damaged, it must be replaced by the manufacturer, its After-Sales Service Department or a similarly qualified person to avoid danger.

• OPERATING PRINCIPLE

The water contained in the tank arrives in the cavity via a pipe. This water is transformed into steam when it comes into contact with a hot surface located in the lower part of the cavity:

this is the steam generator.

There is no need to add water to the cooking dish. To guarantee REAL STEAM COOKING, your oven comes with specially designed cookware that will allow for perfect cooking.

Warning
 You **MUST** fill the water tank to the max. level before cooking. Return the tank to its housing by firmly pushing **ALL THE WAY** until you feel the tank **LOCK INTO POSITION**.

Warning
 When in use, the appliance becomes hot. Hot steam will escape when you open the door of the appliance. Keep children away.

• INTRODUCTION TO YOUR OVEN

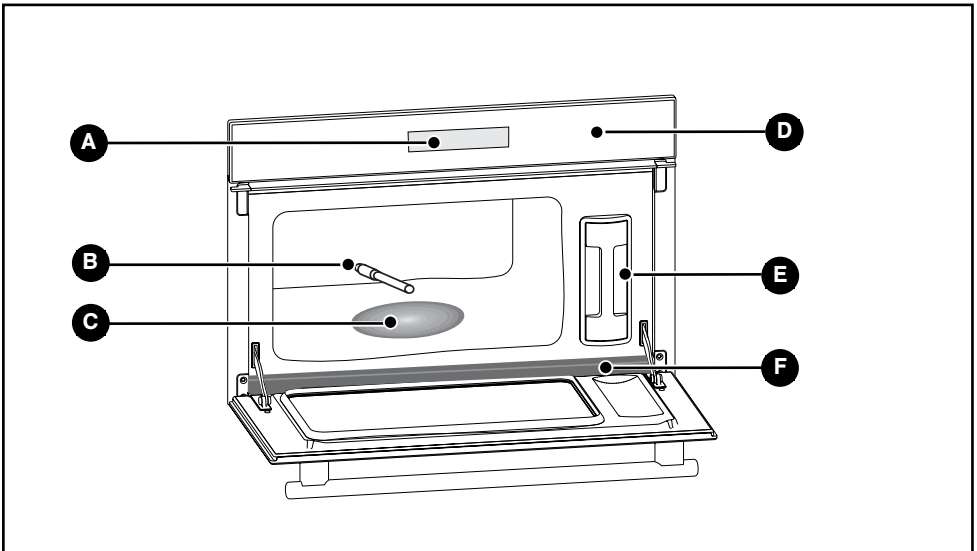

A Display

B Water intake tube

C Steam generator

D Control panel

E Tank

F Gutter

• ACCESSORIES

• Food dish (fig.1)

Pierced stainless steel cooking dish to prevent contact between food and the condensation water.

• Condensate dish (fig.2)

Dish that makes it possible to recover the condensation water.



Tip

When cooking place the fig.1 dish on the fig.2 dish in reverse order so that that do not fit into each other (see diagram).

When storing place the fig.1 dish on the fig.2 dish in the same order so that that fit into each other.

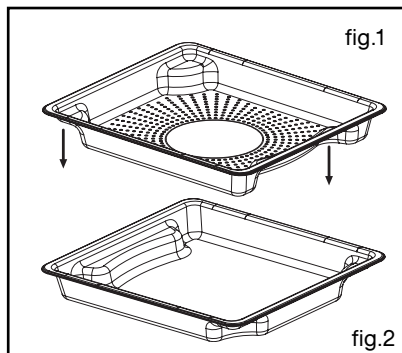

• Grid (fig.3)

Stainless steel removable support grid: it must be placed in the oven.



Tip

The cookware may be cleaned in the dishwasher.

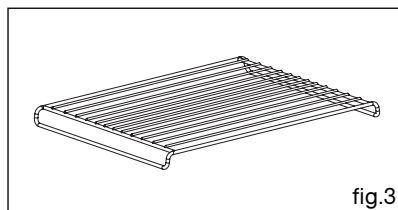

• Removable tank (fig.4)

Tank that allows for independent water supply to the oven.

Its capacity is approximately one litre (maximum level).



Tip

The cookware may be cleaned in the dishwasher.

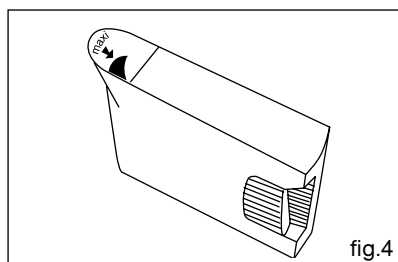

Warning

Demineralised water must not be used (not for human consumption).

• INTRODUCTION TO THE PROGRAMMER

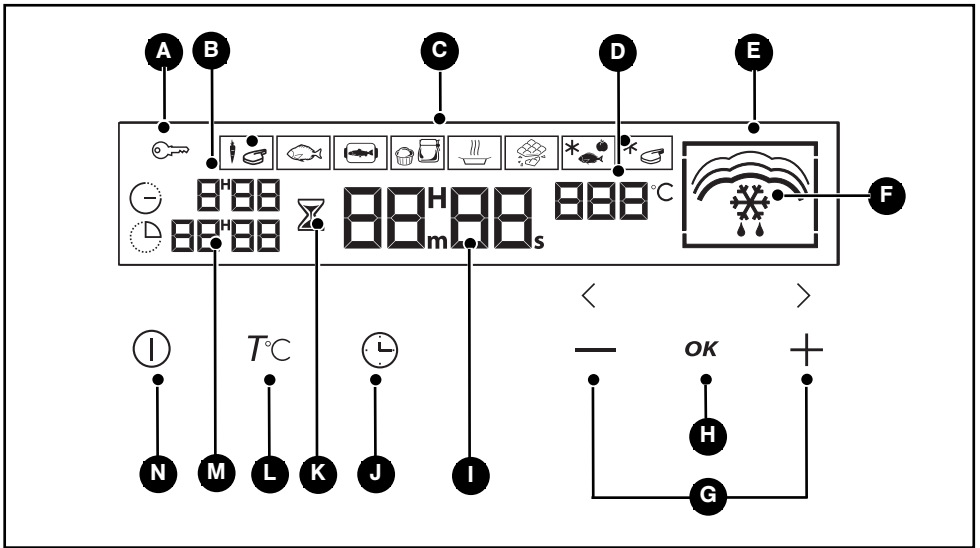

- A** Control panel lock indicator (child safety device)
- B** Cooking time indicator
- C** Cooking modes display
- D** Oven temperature display.
- E** Water circuit problem indicator
- F** Cooking time indicator
- G** Touch controls
- H** Touch controls for validating settings
- I** Clock or timer display
- J** Adjust cooking times/cooking end time and clock settings
- K** Timer indicator
- L** Temperature adjustment
- M** Cooking end time display
- N** Start/Stop

• How to set the time

- When supplied with electricity

The display flashes at 12:00 (fig.1)

Set the time by pressing the + or - touch controls (holding your finger on the touch control allows you to scroll through the numbers rapidly) (fig.2).

Example: 12:30

Press the **OK** button to confirm.

The display stops flashing.

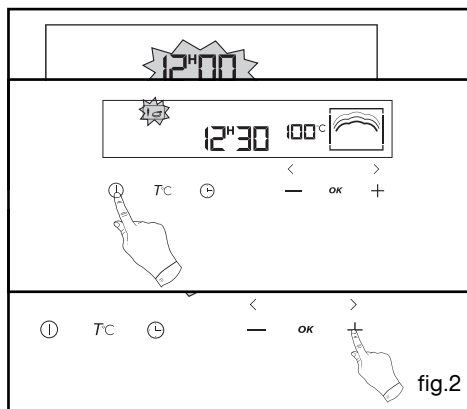

• How to set the time

- To set the time on the clock

Press and hold the \oplus touch control for a few seconds until the display is flashing (fig.1), then release.

Audible beeps indicate that it is now possible to set the time.

Adjust the clock setting with the + and - touch controls (fig.2).

Press the **OK** button to confirm.



• COOKING TIMES PROGRAMMED FOR DIFFERENT FUNCTIONS

Cooking Temperature °C	Time preprogrammed	Min. setting time	Max. setting time
100	25 minutes	5 minutes	1 hour
85	15 minutes	5 minutes	1 hour
75	15 minutes	5 minutes	1 hour
90	20 minutes	5 minutes	1 hour
95	30 minutes	5 minutes	1 hour
80	15 minutes	5 minutes	1 hour
55	30 minutes	5 minutes	1 hour
60	30 minutes	5 minutes	1 hour

IMMEDIATE STEAM COOKING AT 100°C

YOUR OVEN HAS 8 STEAM COOKING FUNCTIONS



Warning

Never turn on the oven without first putting water in the tank.

Press once on the ① touch control to select

the  function (fig.1).

Press the **OK** button a second time to access the cooking time settings.

SETTING THE COOKING TIME:

- 0:25 flashes (fig.2).

- Adjust by pressing the + or - buttons.

Example: 30 minutes

SETTING THE TEMPERATURE WITH THE FUNCTION ONLY :

- Press the **T°C** touch control until the “°C” symbol begins flashing (fig.3).

- Adjust by pressing the - touch control to change the temperature.

Example: 90°C

- Make sure that the door is firmly closed.

Confirm your selection by pressing **OK**.

Your oven starts by counting down second by second.

If necessary, cooking can be stopped by pressing on ① for 1 second.

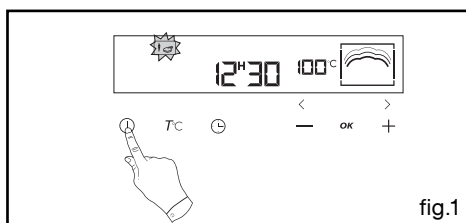

fig.1

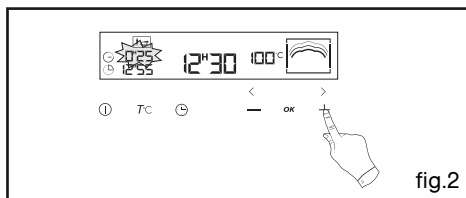

fig.2

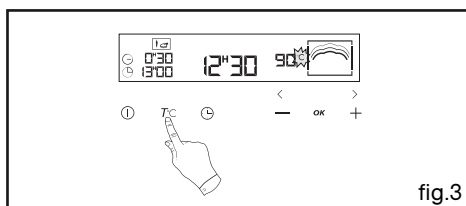

fig.3



Tip

To avoid compromising the cooking results, do not open the appliance door during cooking.

• CANCELLING COOKING IN PROGRESS

You can stop the cooking at any time by pressing the ① touch control (press and hold for approximately one second).

If steam generation has not yet begun (approximately 1 minute), the oven stops immediately and the time disappears.

If steam generation has already begun, the time converts to 3 minutes; a countdown begins and the steam escapes before the door is opened.

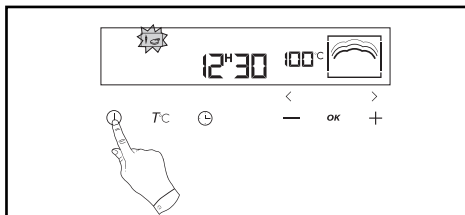

• AT THE END OF A COOKING PROGRAMME

0m00s is displayed. The display animation ceases. Discontinuous beeps are emitted for three minutes.

To silence the beeps, press the ① touch control or open the door.



Warning

You MUST empty the tank.

• WATER MANAGEMENT

In the event of a water circuit-related problem during cooking, the indicator appears and a beep is emitted.(fig.1).

This error is specifically associated with:

- An empty tank.
- A poorly fitted tank.

After checking these two items, cooking automatically restarts as soon as the door is closed.



• DELAYED COOKING

• Delayed cooking with programmed cooking end

Delayed cooking is possible in all cases **except for defrosting functions**:



- Proceed as for an immediate cooking programme, after entering the cooking time,
 - Press the “end of cooking”  touch control, the end of cooking time appears and flashes, to indicate that it is now possible to set the time.

Example: It is 12:30 (fig.1).

You programmed a cooking time of 25 minutes.

The displayed end of cooking time is 12:55.

- Adjust the end of cooking time by pressing the + or - touch controls.

Example: End of cooking 14:00 (fig.2).

- Confirm with the “End of cooking” .

Once the cooking end time has been programmed, the time comes back on the display.

After these steps, oven heating is delayed so that cooking ends at 14:00.

When the cooking cycle is finished, a series of beeps is emitted for several minutes. You can stop the beeps by pressing  for one second.

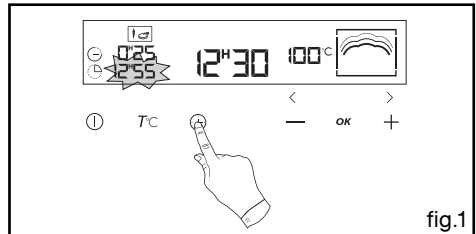

fig.1

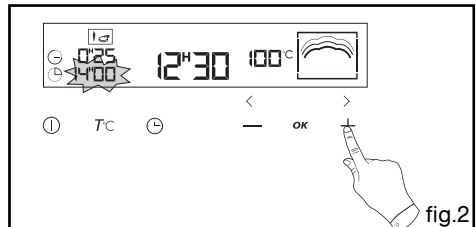



fig.2



Tip:

You can view or change the end of cooking by pressing the  touch control. To cancel your programme, press the START/STOP touch control.

• USING THE TIMER FUNCTION

- Your oven's programmer can be used as an independent timer that allows you to count down a time without operating the oven.

In this case, the timer display has priority over the clock display.

- Press the  touch control 3 times (fig.1).

The 0m00s symbol flashes.

- Adjust the chosen time by pressing the + or - touch controls (max 59 minutes 50 seconds) (fig.2).

- Press the **OK** button to confirm.

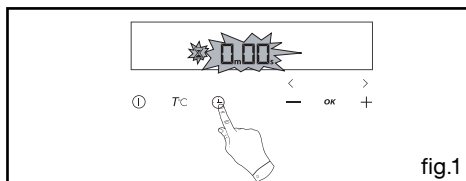

fig.1

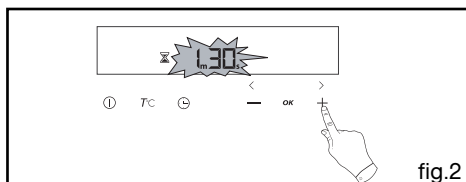

fig.2

The display stops flashing after a few seconds and the timer starts working, counting down the time in seconds.

Once the time has expired, the timer emits a series of beeps to notify you.

The beeps can be stopped by pressing any touch control.



Warning

*It is possible to change or cancel the timer programme at any time by turning it to 0:00 and pressing the **START/STOP**.*

• CONTROL PANEL LOCKING (CHILD SAFETY) OVEN OFF

You have the option of preventing access to the oven controls by taking the following steps:

When the oven is off, hold down the **OK** touch control for a few seconds; a "key" will then be displayed on the screen -> access to the oven controls is now blocked (fig.1).

To unlock access, hold down the **OK** touch control for a few seconds.

The oven controls are once again accessible.

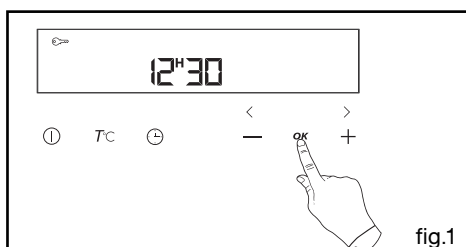

fig.1



Warning

You cannot lock the oven if you have programmed a cooking cycle.

• DISPLAY STAND-BY MODE

- To limit your oven's consumption of energy when it is not in use, you may put it on STAND-BY MODE.

To do so, perform the following procedure:

ACTIVATION OF STAND-BY MODE:

- Your oven must be in time display mode.
- Press the + and - touch controls simultaneously for 5 seconds (fig.1).
- Your display indicates "LCD OFF" (fig.2).
- Release the buttons.
- 30 seconds later, your display will turn off.



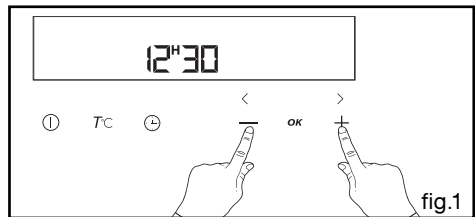
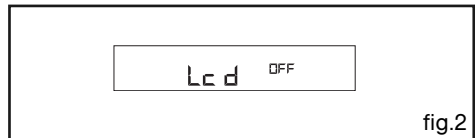
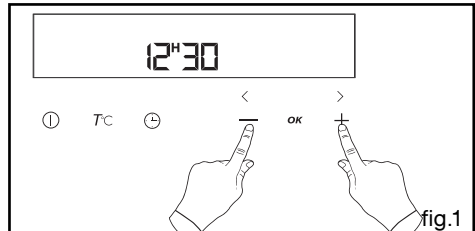



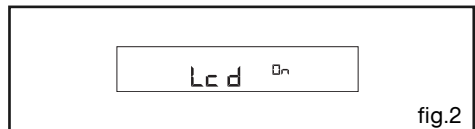

Your oven is now in stand-by mode, it will automatically turn off after 30 seconds in time display mode.



DEACTIVATION OF STAND-BY MODE:

- Your oven must be in time display mode.
- Press the + and - touch controls simultaneously for 5 seconds (fig.1).
- Your display indicates "LCD ON" (fig.2)
- Release the buttons.
- You are out of STAND-BY MODE, your display will remain on constantly.

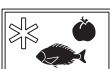

FUNCTIONS Temperature °C	COOKING	COOKING EXAMPLES
 100	Steam cooking mode most often used	Vegetables and meats
 85	For cooking fragile food	Delicate whole fish (trout)
 75	The meat remains iridescent, the collagen does not appear	Cooking delicate fish (sardine fillets, red mullet)
 90	For cooking fragile food, fruit, compotes	Boiled eggs; stuffed tomatoes that maintain their shape. Ramekins, custard creams, etc.
 95		Terrines, chicken liver. Reheating cooked dishes
 80	Low heat	Melting chocolate, butter. Slightly warm fruit for immediate serving
 55	Slow defrosting without cooking	Defrosting fish fillets before breading. Berries that must remain cool (for pies and sauces)
 60		Defrosting meats before grilling (e.g.: sausages)

FOOD whatever the quantity		TIMES	°C	PREPARATIONS	NOTES
VEGETABLES	Artichokes (small)	40 to 45 min.	100	Placed upside down in the dish	<ul style="list-style-type: none"> • These times depend on the type, size and freshness of the vegetables. Follow the indications that appear in the "Preparations" column. • The cooking time remains the same regardless of the quantity to be cooked. <i>Example:</i> 1 or 4 artichokes require the same cooking time. • To check the level of cooking, insert the tip of a knife into the thickest part of the vegetable; if it is cooked there should be no resistance.
	Asparagus	35 to 40 min.	100	For tips only, decrease cooking time	
	Broccoli	18 min.	100	In small bunches	
	Carrots	20 to 22 min.	100	In thin, round slices	
	Celeriac	25 to 30 min.	100	In thin slices	
	Pumpkin	15 to 20 min.	100	In cubes	
	Mushrooms	15 min.	100	In thin strips	
	Cabbage	30 to 35 min. 22 min. 30 to 35 min.	100	Brussels sprouts Cauliflower in small bunches Green, chopped	
	Courgettes	10 to 15 min.	100	In round slices	
	Chinese artichokes	20 min.	100		
	Spinach	20 min. 35 min.	100	(fresh) stir while cooking (frozen) " "	
	Endives	30 min.	100	Core removed, cut in half lengthwise	
	Fennel	22 min.	100	Cut in half	
	Green beans	30 to 35 min.	100		
	Turnips	15 to 20 min.	100	In cubes	
	Fresh peas	20 to 25 min.	100	/	
Leeks	25 min.	100	Cut in half		
Potatoes	25 min. 40 to 45 min.	100	Cut in round slices Whole		
SHELLFISH CRUSTACEANS	Scallops	10 to 12 min.	90	With seasoning	<ul style="list-style-type: none"> • Place the scallops on the grid of the glass dish, add aromatic herbs. • Place the shell fish on a bed of seaweed.
	Mussels/periwinkles	20 to 25 min.	95	With seasoning	
	Crabs/hermit crabs	25 min.	95	/	
	Lobsters	30 to 35 min.	95	Depending on weight	
	Langoustines	12 to 15 min.	90	/	
FRUITS PUDDINGS	Apples/pears/peaches	10 to 15 min.	90	Whole, peeled	<ul style="list-style-type: none"> • Times depend on ripeness.
	Compote	25 min.	95	Fruit in strips	
	Custard creams	10 min.	90	In ramekins	

FOOD whatever the quantity		TIMES	°C	PREPARATIONS	NOTES
FISH	Northern pike	25 to 30 min.	85	Whole (1 kg)	<ul style="list-style-type: none"> * Steaks: round slices of fish of 2 to 3 cm in thickness (180/200g) per person. Insist on very fresh products. Place whole fish in the dish as is or on bay leaves, fennel or other aromatic herbs. As soon as cooking is complete, remove the skin, which will detach easily.
	Cod/hake	13 to 15 min.	85	Steaks (180 g)*	
	Sea bream	20 to 25 min.	85	Whole (1kg)	
	Haddock	15 min.	75	Filets	
	Herring	20 min.	85	Whole (200g)	
	Pollack/black cod	15 to 20 min.	85	Steaks (180 g)	
	Monkfish	15 min.	80	Depending on thickness	
	Mackerel	20 min.	85	Whole (250g)	
	Atlantic cod	15 min.	75	Filets	
	Ray	25 to 30 min.	80		
	Red mullet	15 min.	80	Whole (200g)	
	Red mullet/Sole	10 min.	75	Filets	
	Spotted dogfish	20 min.	85	Thick steaks (6 to 10 cm in length)	
	Salmon	15 to 20 min.	85	Steaks (180/200 g)	
	Tuna	20 to 25 min.	100	Steaks (180/200 g)	
Trout	20 to 25 min.	100	Whole (200g)		
Whole (1kg)			13 to 15 min.		
MEATS	Beef	15 to 30 min.	100	Roast 800 g.: 55 to 60 min.	<ul style="list-style-type: none"> Then brown under the grill in another dish.
	Pork (tenderloin)	25 min.	100	Chicken thighs: 35 to 40 min.	
	Poultry (breast) (stuffed)	20 to 25 min.	100	Roast turkey: 50-60 minutes.	
	Sausages	25 min.	95		
	Boudins	20 min.	90	Mortreau 400 g	
EGGS	Start with very fresh eggs kept at room temperature	7 min.	100	<u>Boiled</u> : placed directly on the grid.	
		8 min.	100	<u>Softboiled</u> : placed directly on the grid.	
		10 to 12 min.	100	<u>Hard-boiled</u>	
		5 to 6 min.	100	<u>Sunny side up</u> : broken in an individual dish placed on the grid and covered with cooking wrap.	
			90	<u>Cocotte</u> : See detailed recipes.	
RICE, PASTA SEMOLINA	Place directly in a dish then cover with water or milk. The steam is not enough to saturate these inflating foods. Place a sheet of aluminium foil on the dish to prevent water droplets from falling in.				
	Rice pudding	30 min.	100	100 g rinsed rice - 20 cl milk - 2 dessertspoons sugar	<ul style="list-style-type: none"> Fluff with a fork when cooking is complete.
Semolina	20 min.	100	200 gr (1/4 litre water)		

• **CLEANING THE OUTER SURFACES**

To clean both the electronic programmer window and the oven door, use a window washing product applied to a soft cloth.

Do not use abrasive cleaning products or hard metallic scrapers for cleaning the oven's glass door, which could scuff the surface and cause the glass to shatter.

• **CLEANING THE CAVITY (AFTER EACH USE)**

Wipe the cavity with a dry cloth after the steam generator has cooled or let the cavity air-dry by leaving the door open.

• **CLEANING THE WATER INTAKE TUBE (ONCE A MONTH)**

Remove the water intake tube by unscrewing it

Remove any hard-water deposits that may be inside (using a thin, pointed object such as a thin skewer or a knitting needle).

• **CLEANING THE STEAM GENERATOR (ONCE A MONTH)**

Pour 1/2 cup of white alcohol vinegar on the generator.

Let sit for a few minutes, then clean and rinse with water.

Do not use sponges or abrasive powders, nor coffee maker cleaning agents.

• **CLEANING THE GUTTER**

Remove this gutter by pulling it upward. Wipe it off and return it to its position using the three notches provided.



Warning

The oven should not be cleaned with a steam cleaner.

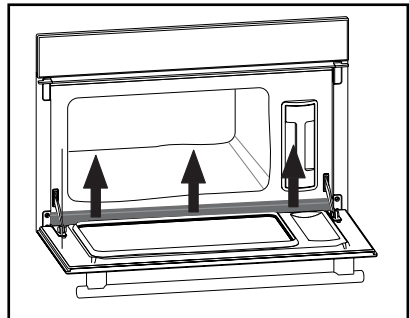

If you have a doubt about the correct functioning of your oven, this does not necessarily mean that there is a malfunction. *In any event, check the following items:*

YOU OBSERVE THAT...	POSSIBLE CAUSES	WHAT SHOULD YOU DO?
<i>Your display does not light up.</i>	<ul style="list-style-type: none"> - <i>Oven is not connected to power source.</i> - <i>Electronic board is not functioning.</i> 	<ul style="list-style-type: none"> - <i>Check that the appliance is receiving electricity (good fuse).</i> - <i>Call the After Sales Service Department.</i>
<i>Water or steam leak around the door during cooking.</i>	<ul style="list-style-type: none"> - <i>The door is not properly closed.</i> - <i>The door seal is defective.</i> 	<ul style="list-style-type: none"> - <i>Call the After Sales Service Department.</i>
<i>The oven light is not working.</i>	<ul style="list-style-type: none"> - <i>The light is out of order.</i> - <i>The oven is not connected or the fuse is not working.</i> 	<ul style="list-style-type: none"> - <i>Replace the light.</i> - <i>Connect the oven or replace the fuse.</i>



Warning

- *Repairs to your appliance should only be performed by professionals. Non-standard repairs may be a source of danger for the user.*



Tip

In all circumstances, if your efforts are not sufficient, contact the After-Sales Service Department without delay.

**Warning**

- Disconnect your oven before performing any task on the bulb to avoid the risk of electric shock and, if necessary, let the appliance cool down.

**Tip**

To unscrew the port and the bulb, use a rubber glove, which will make disassembly easier.

• CHANGING THE BULB

The bulb is located at the back right of your oven's cavity.

- Disconnect your oven before performing any task on the bulb to avoid the risk of electric shock.
- Turn the view port a quarter turn to the left.
- Unscrew the bulb in the same direction.

Bulb specifications:

- 15 W - 220-240 V
- 300°C - E 14 cap

- Replace the bulb then reposition the view port, making sure the joints are correctly positioned.
- Reconnect your oven.

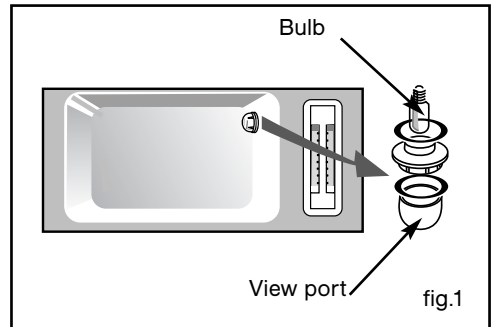

• REPAIRS

Any repairs that are made to your appliance must be handled by a qualified professional authorised to work on the brand. When you call, mention your appliance's complete reference (model, type, serial number). This information appears on the manufacturer's nameplate (fig.1).

SPARE PARTS

During any servicing, ask that they use only genuine replacement parts.

